

Authority to alter facilities in residential and small business premises

Engineering

Document number	F0002-31-11678
Document category	Guide
Author	Engineering
Approver (owner)	National Engineering Manager, External Networks
Status	Approved
Issue date	17 SEPT 2015
Revision number	1.0





Disclaimer

This document is provided for information purposes only. This document is subject to the information classification set out on this page. If no information classification has been included, this document must be treated as UNCLASSIFIED, SENSITIVE and must not be disclosed other than with the consent of **nbn** co. The recipient (including third parties) must make and rely on their own inquiries as to the currency, accuracy and completeness of the information contained herein and must not use this document other than with the consent of **nbn** co.

Copyright © 2015 **nbn** co limited. All rights reserved.

Document control

Revision history

Date	Revision	Details
17 SEPT 15	1.0	Approved



Contents

1 About this document	6
1.1 Purpose	6
1.2 Objective	6
1.3 Scope	6
1.3.1 In scope	6
1.3.2 Out of scope	6
1.4 Audience	6
1.5 Related documents	7
1.6 Changes in this revision	7
2 Overview	8
2.1 General	8
2.2 Regulatory	8
2.2.1 Laws	8
2.2.1.1 Telecommunications ACT 1997	8
2.2.1.2 Criminal Code 1995 (Cth)	8
2.2.1.3 Common law	9
3 Authorisation	10
3.1 Rationale for limiting authorisation	10
3.1.1 Materials and practices must be to nbn standards	10
3.1.2 nbn network	10
3.1.2.1 Network boundary point	11
4 Authorised work	14
4.1 General terms and conditions	14
4.2 Authorised activities	16
4.3 Scope of authorised work	17
4.3.1 Replacement of the first TO	17
4.3.2 Relocation of the first TO	17
4.3.3 Fixed wall phone or other hard-wired telephones	17
4.3.3.1 Replacement or relocation	17
4.3.4 Star-wired TOs	18



4.3.5	Additional TOs.....	18
4.3.6	Reconfiguration of nbn wiring.....	18
4.4	Cabling in the building.....	20
4.4.1	Cable installation	20
4.4.2	Building cable entry	21
4.5	Cable jointing.....	23
4.6	Change over switch	23
4.7	VDSL2 centralised filter	24
4.8	Existing NTD.....	26
4.9	nbn NTD.....	27
4.10	Disconnection of nbn lead-in cabling.....	28
4.11	Use of existing telecom lead-in poles for customer cabling	28
5	Activities not authorised.....	30
6	Glossary	32
Appendix A	Approved Lead-In Equipment.....	33

Figures

Figure 1.	Typical underground residential installation first TO as Network Boundary Point.....	11
Figure 2.	Typical underground residential installation NTD as Network Boundary Point.....	11
Figure 3.	Typical aerial residential installation with first TO as Network Boundary Point.....	12
Figure 4.	Typical aerial residential installation with NTD as Network Boundary	12
Figure 5.	Typical internal residential installation with first TO as Network Boundary Point	13
Figure 6.	Typical wiring to facilitate “mode 3”	19
Figure 7.	2pr – 5pr cable minimum bend radius	21
Figure 8.	Building cable entry	22
Figure 9.	Typical VDSL2 centralised filter installation within external NTD for existing star legacy wiring	25
Figure 10.	Typical nbn VDSL2 centralised filter faceplate installation in legacy star-wired installation.....	25
Figure 11.	nbn connection box 10023542.....	33
Figure 12.	nbn compact NTD 10023656.....	34
Figure 13.	nbn with unterminated cables	34
Figure 14.	nbn NTD with VDSL2 centralised filter installed.....	34



Figure 15. nbn NTD 10023544	35
Figure 16. nbn faceplate	36
Figure 17. nbn VDSL2 centralised filter	37
Figure 18. nbn VDSL2 centralised filter	37
Figure 19. Connectors and crimping tool	38



1 About this document

1.1 Purpose

This document authorises registered cabling providers to move, remove or alter certain **nbn** owned copper network cabling and assets.

1.2 Objective

This document defines the type of work, and the areas of the network, that can be altered to provide a service to end users.

1.3 Scope

This Document applies to premises and local areas of the network where **nbn** copper pairs typically terminate at a Telecommunications Outlet (TO) or Network Terminal Device (NTD).

1.3.1 In scope

nbn facilities on residential and small business premises fed by copper cables of 10 pair or less.

1.3.2 Out of scope

The document does not apply to:

- copper distribution network assets which are not owned by **nbn**
- retail service provider (RSP) assets
- **nbn** distribution network
- coaxial cabling networks
- optical fibre networks
- cabling that terminates on a Main Distribution Frame (MDF)
- payphones
- cabling in hazardous areas, such as fuel dispensing stations
- cabling in high voltage substations or power generating stations

1.4 Audience

Cabling providers working in residential and small business premises.



1.5 Related documents

Document	Owner and link
[1] AS/CA S009:2013	Australian Standard
[2] Telecommunications Act 1997	Australian Government
[3] Criminal Code 1995	Australian Government

1.6 Changes in this revision

This is the first release of this document.



2 Overview

2.1 General

Cabling providers working in residential and small business premises may need to alter **nbn**'s lead-in cabling and network boundary facilities to satisfy the customer's requirements. **nbn** authorises cabling providers to make limited alterations to **nbn** facilities in or on the building as long as the work is carried out to **nbn**'s requirements.

2.2 Regulatory

Generally **nbn** owns the facilities it provides for the purpose of supplying **nbn** services to the network boundary, whether or not they become fixtures. **nbn** will alter its facilities in customer premises, on request, at appropriate charges. Alternatively, **nbn** may authorise non-**nbn** cabling providers to perform such alterations on terms and conditions stipulated by **nbn**.

A person who installs or maintains cabling for connection to a telecommunications network ("cabling work") must comply with the Telecommunications Act 1997. The person must be registered to perform cabling work by an ACMA-accredited body (a "cabling registrar"). It is a condition of the registration for the person to comply with the wiring rules (Australian Standard AS/CA S009).

Clause 5.13 of AS/CA S009:2013 prohibits a cabling provider from moving, removing or altering any lead-in cabling or network boundary facilities without the prior written authorisation of the carrier. However, the Note to Clause 5.13 of AS/CA S009:2013 clarifies that if a carrier publishes a document authorising cabling providers to alter its facilities (such as this Document), such a document will be taken to be the prior written authorisation of the carrier as long as any terms and conditions set out in the document are adhered to by the cabling provider.

2.2.1 Laws

All telecommunications facilities owned or operated by a licensed carrier or a carriage service provider (e.g. **nbn**) are protected by various laws, whether or not they are located on the carrier's property, public property or private property (e.g. in customer premises). A summary of applicable laws follows.

2.2.1.1 Telecommunications ACT 1997

In accordance with Clause 47 of Schedule 3 of the Telecommunications Act 1997, **nbn** continues to have ownership of facilities that it provides in customer premises even if they have become fixtures.

2.2.1.2 Criminal Code 1995 (Cth)

A person is guilty of an offence under Section 474.6 of the Criminal Code 1995 (Cth) if:

- the person tampers or interferes with a facility owned or operated by a carrier or a carriage service provider
- the person tampers or interferes with a facility owned or operated by a carrier or a carriage service provider and this conduct results in hindering the normal operation of a carriage service supplied by a carriage service provider



Note: The main distinction between a carrier and a carriage service provider is that a carrier owns the network infrastructure over which carriage services are supplied, while a carriage service provider supplies carriage services using the network of one or more carriers.

Each offence carries the risk of a substantial fine and/or imprisonment upon conviction. However, Section 474.3 of the Criminal Code 1995 (Cth) makes provision for a person to do anything for or on behalf of a carrier or a carriage service provider. Through this Document, **nbn** authorises a registered cabling provider to alter certain **nbn** facilities, on the specified terms and conditions, under Section 474.3 of the Criminal Code 1995 (Cth).

2.2.1.3 Common law

Common law is “unwritten law” based on custom or court decision. Under the common law of negligence, persons owe **nbn** a duty of care to take all reasonable precautions not to damage **nbn**’s facilities. **nbn** may have a right to bring a claim against a cabling provider who interferes with or damages **nbn**’s facilities or services resulting in **nbn** suffering loss.



3 Authorisation

nbn supplies telecommunications network services to customers using the existing local copper network.

In order for **nbn** to supply network services **nbn** may be required to install or replace some of the existing facilities at the customer premises and must maintain these facilities for continuance of the service or supply of subsequent services.

3.1 Rationale for limiting authorisation

nbn limits and controls authorisation access to its network for the following reasons:

- **nbn** has a statutory obligation to supply fixed line broadband services.
- In certain circumstances **nbn** may install Over Voltage Protection (OVP) at the customers building.
- In some cases **nbn** may install devices or equipment at the customer premises that are essential to the operation and the performance of network.

nbn has no legal obligation to authorise cabling partners to alter **nbn** facilities within customer premises. However it is not **nbn**'s intention to impede cabling work that may include alterations to **nbn**'s network facilities if, in **nbn**'s opinion, a cabling provider is capable of carrying out such alterations without adversely affecting **nbn** or the customer. Accordingly, **nbn** will authorise cabling providers to make limited alterations to its facilities in or on a customer's building under the specified terms and conditions.

nbn reserves the right to cancel this Document, to revoke or vary any authorisation conveyed in this Document, or to vary the terms and conditions prescribed in this Document, either generally or selectively, at any time without notice in its absolute discretion.

It will be the responsibility of the cabling provider to ensure that this Document has not been cancelled, that the latest version of this Document is used, and that relevant laws, codes, standards or other regulatory requirements are complied with.

3.1.1 Materials and practices must be to **nbn** standards

nbn specifies the use of certain materials and practices within the confines of its network (i.e. up to and including the network boundary) because **nbn** must maintain these facilities. **nbn** may only carry these standard materials for repair work or alterations. Thus it is a general condition of any **nbn** authorisation contained herein, for the cabling provider to use the same materials and practices as **nbn** would normally use on its side of the network boundary.

3.1.2 **nbn** network

nbn owns or operates its facilities up to the **nbn** network boundary.

Generally, **nbn**-owned equipment or cabling on the customer side of the network boundary will be identified as **nbn** property e.g. labelled or stamped "**nbn**".

3.1.2.1 Network boundary point

Where the **nbn** lead-in cable is not connected to a customer MDF or NTD, the network boundary point for each line supplied to a building will be the first TO (“first socket”) after the building entry point or, in some cases, an fixed wall phone or other, hard-wired telephone. The first TO will be the network boundary point with the majority of single dwellings throughout Australia. In such cases, **nbn** accepts responsibility for installation and repair of a standard **nbn** telephone service up to, and including, the first TO.

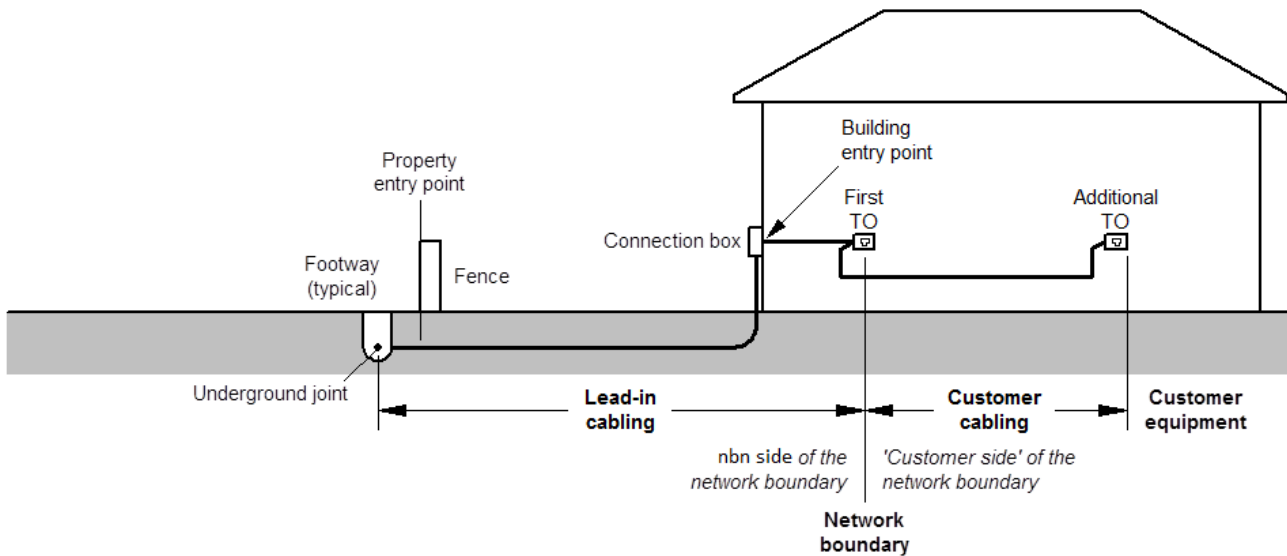

Figure 1. Typical underground residential installation first TO as Network Boundary Point

Where the **nbn** lead-in cable is connected to an external NTD, this defines the network boundary point.

Figure 2 details the Network Boundary point for underground cabling when an NTD is installed.

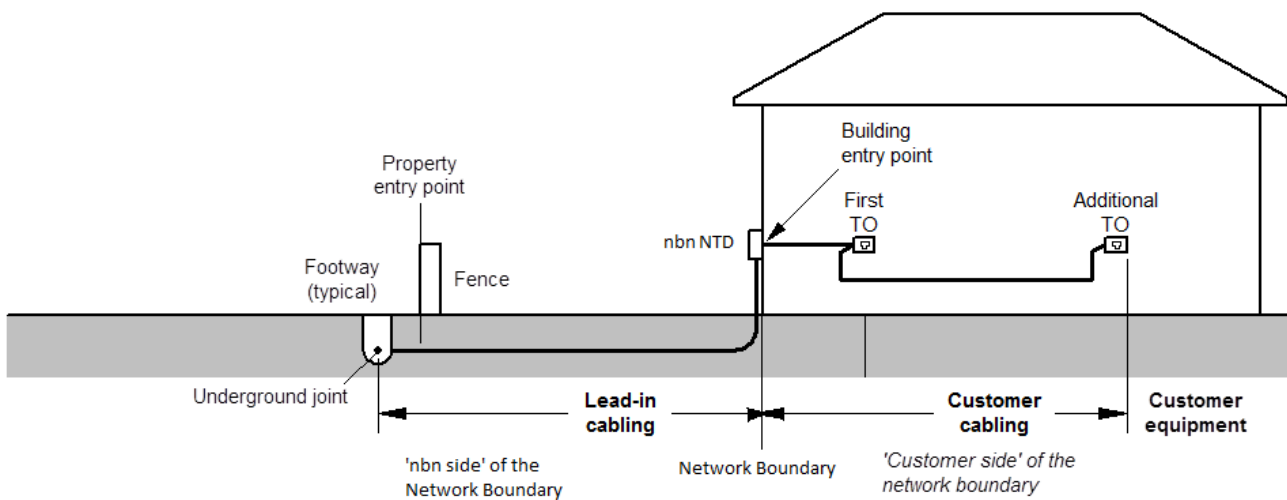

Figure 2. Typical underground residential installation NTD as Network Boundary Point

The same rules apply for aerial fed lead-in cabling, if an NTD is not present, then the first TO is the network boundary point. Figure 3 details typical aerial fed premises with the first TO as the network boundary point.

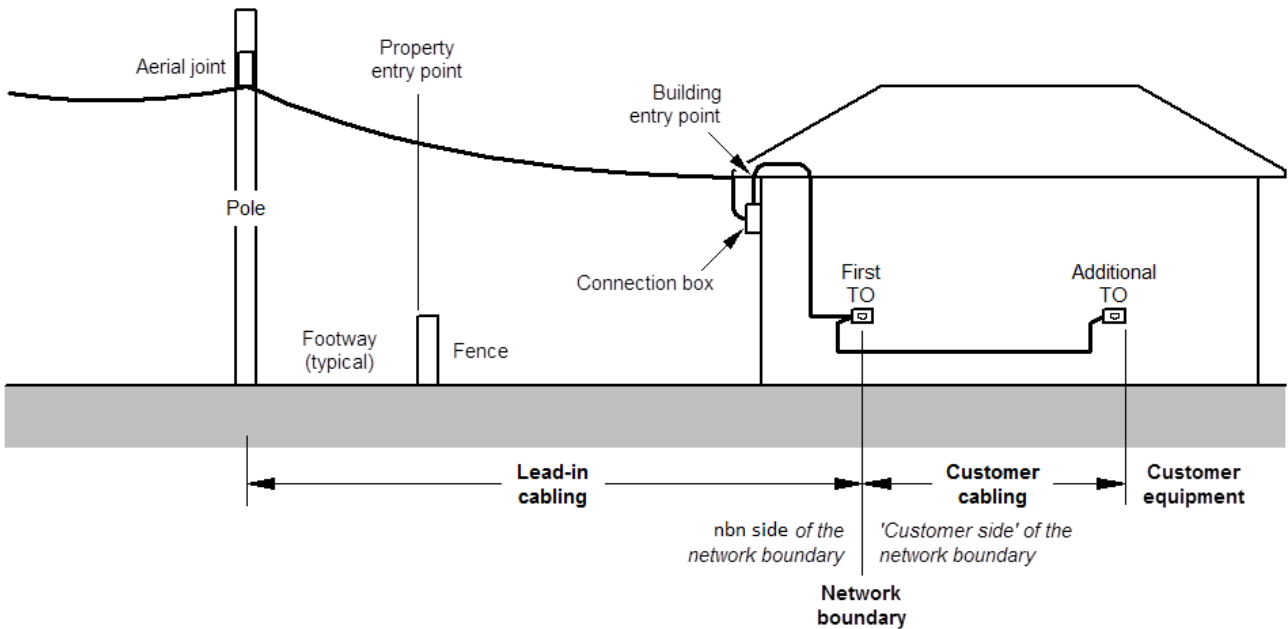

Figure 3. Typical aerial residential installation with first TO as Network Boundary Point

Figure 4 shows a typical aerial installation with the NTD as the network boundary point.

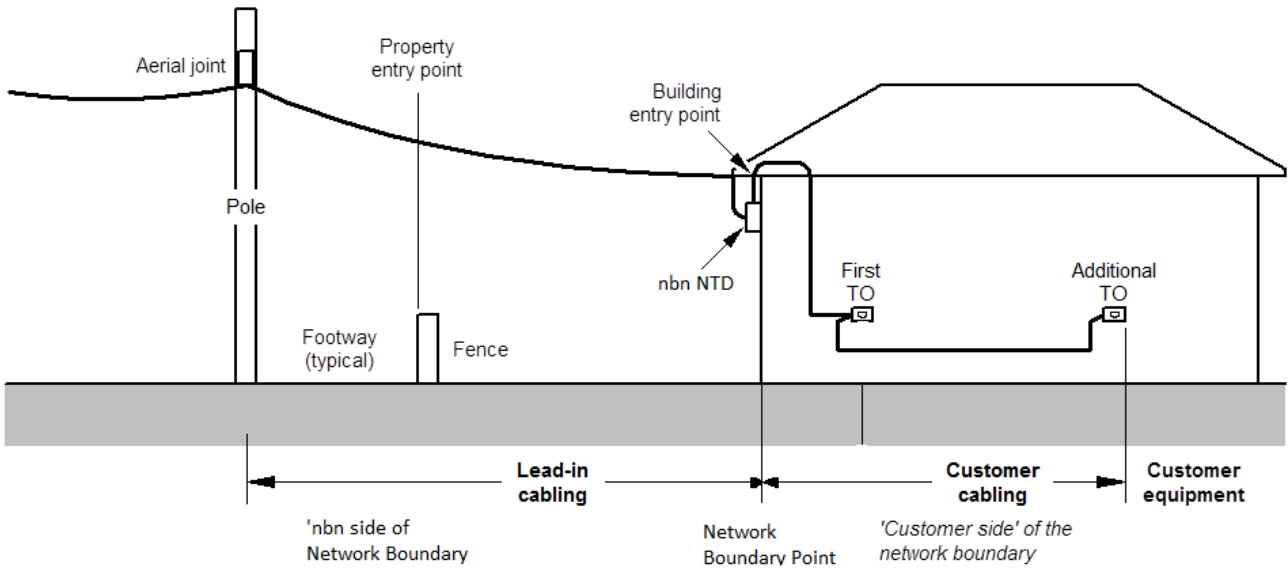

Figure 4. Typical aerial residential installation with NTD as Network Boundary

Where an NTD is installed, it is the network boundary for all lines connected to it; otherwise the network boundary defaults to the first TO inside the building (unless the line connects to a distributor, in which case the distributor becomes an MDF which will be the network boundary point).

Note: For a detailed description of the network boundary, refer to the Australian Standard AS/CA S009, Installation requirements for customer cabling (Wiring rules).

Prior to “deregulation” of premises cabling in 1989, it was common practice in some areas to star wire TOs from a connection device or joint in the lead-in cable. In such cases, each star-wired TO is potentially the network boundary for the cable terminated on it. In the deregulated environment, this creates problems for both **nbn** and the cabling provider, but **nbn** is not obliged to reconfigure existing star-wired installations.

This document does not legally change the network boundary from the first TO to the building entry point or to any intermediate connection device or joint in the lead-in cabling — the network boundary is determined by legislation and detailed in [1]AS/CA S009:2013 and remains at the first TO, NTD or MDF, as applicable. This document authorises a cabling provider to make limited changes to **nbn**’s network facilities, including changing the location of the network boundary point to the building (e.g. changing the position of the first TO from one part of the building to another, or changing the network boundary from the first TO to an **nbn** NTD)

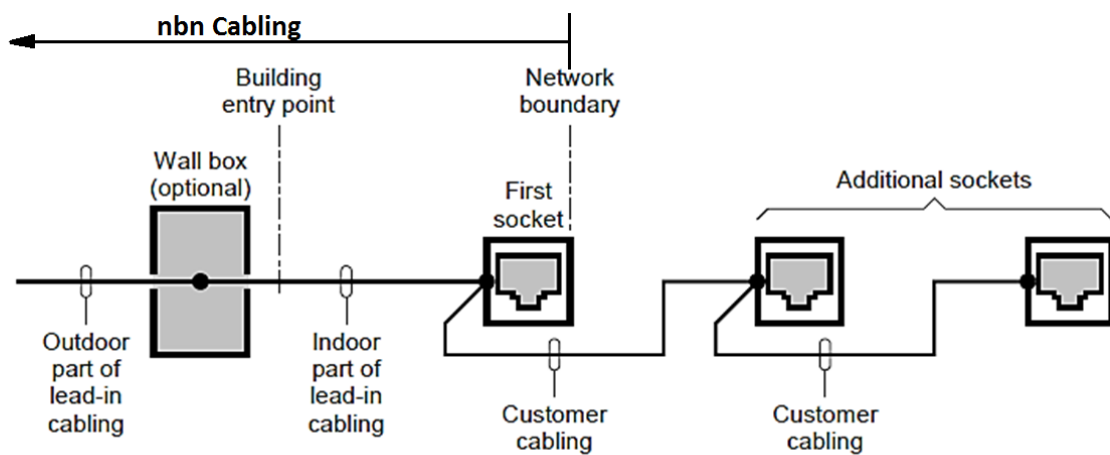

Figure 5. Typical internal residential installation with first TO as Network Boundary Point



4 Authorised work

This section describes the type of work that is authorised by **nbn** and sets out the general terms and conditions that apply to all activities plus further terms and conditions that apply to each specific activity.

If an activity is not listed, it is not authorised.

Examples of specific activities that are not authorised are listed in Section 5 . Activities not authorised.

4.1 General terms and conditions

nbn authorises a cabling provider to do certain work on **nbn** facilities, as set out in this Document, subject to the general terms and conditions below.

The person performing the cabling work (cabling provider) must be a registered cabling provider in either the Restricted or Open category.

All registered cablers are required to undertake appropriate training modules to ensure that they are competent to perform the cabling work according to the Wiring Rules [1]AS/CA S009:2013, which ensure safety to consumers, cablers and the network.

Note: While by law cable registration is not required to perform work on **nbn**'s side of the network boundary, **nbn** requires the person to be a registered cabling provider as a condition of this document as a measure of competency to do the work and to ensure that the requirements of the Cabling Provider Rules are met in case the work also involves any cabling activity on the customer's side of the network boundary.

The cabling provider must ensure that he/she is familiar with all applicable legal and regulatory requirements for the performance of this work and that he/she complies with all laws, regulations, standards and codes of practice applicable to this work.

The cabling provider acknowledges that he/she is responsible for the restoration of faulty or substandard work if requested to do so by **nbn** or the customer:

- **nbn** reserves the right to seek damages from the cabling provider if **nbn** incurs costs due to any work performed by the cabling provider on **nbn**'s facilities.
- **nbn** retains ownership of any **nbn** facilities so worked on whether re-used or replaced.
- The cabling provider acknowledges that he/she is not performing any work under this Document in **nbn**'s name nor is he/she a contractor or employee of **nbn**.
- The cabling provider must not represent or give an impression to customers or third parties that he/she is performing work as an employee or a contractor of **nbn**.
- The cabling provider must not seek any remuneration from **nbn** for any work performed.
- The cabling provider agrees to indemnify **nbn** against any liability, loss, damage, costs or expenses incurred or suffered by **nbn** that is caused by any act or omission of the cabling provider whether negligent or not, or which arises from any default under the terms and conditions of this Document.



- The cabling provider must not do anything that may affect the safety, integrity or proper functioning of the **nbn** network or the safety of the customer or any other person. The cabling provider must not use substances or material deleterious to health or safety or which could adversely affect the functioning of the **nbn** network.
- The cabling provider must ensure that he/she does not cause unnecessary detriment, inconvenience or damage to **nbn**, the customer or a third party
- The cabling provider must not do any act or thing that is prejudicial to the goodwill, commercial reputation or overall public image of **nbn**.
- The cabling provider must keep proper records of the work performed under this Document.
- Notwithstanding anything contained in this Document, the cabling provider must take all reasonable steps to ensure that lightning surge suppressors or any equipment that may be necessary for the safety and proper functioning of the installation are not bypassed or disconnected.
- The cabling provider must not create any star-wired connections from an intermediate connection point in the lead-in cabling i.e. between the property entry point and the first TO, unless the intermediate connection point is:
 - A Centralised Filter provided in accordance this document
 - an **nbn** NTD provided in accordance with this document
- The cabling provider must not render any **nbn**'s installation unusable e.g. by removing the **nbn** cabling or not terminating the **nbn** lead-in cable at a TO that is readily accessible by the customer, unless this is necessary for the purpose of renovation, demolition or relocation of the building.
- The cabling provider must not connect **nbn** lead-in cable to:
 - a customer MDF
 - or directly to a home networking box or a patch panel of any description
- Any new cabling to the first TO must be installed in a manner that enables safe access and/or replacement of such cabling by **nbn** installers subsequent to its installation.
- Where the location of the network boundary is changed, the customer must be notified immediately in writing of this fact.
- Any waste material e.g. used wire, cable, conduit, etc. must be safely and properly disposed of in accordance with applicable laws.
- All works must adhere to Australian Standard AS/CA S009 and The Building Code of Australia (BCA).



4.2 Authorised activities

Subject to the terms and conditions set out herein, **nbn** authorises a cabling provider to:

- Replace **nbn**'s existing first TO ("first socket") with another TO of a type approved by **nbn**.
- Relocate **nbn**'s existing first TO ("first socket") to another location within the same building.
- Relocate a fixed wall phone or other hard-wired telephone (other than a payphone) to another location within the same building, or replace it with a TO for the purpose of connecting other customer equipment.
- Disconnect a fixed wall phone or other hard-wired telephone (other than a payphone) if it is no longer required.
- Relocate a TO or provide an additional TO where the TOs are cabled from a common ("star-wiring") point in the lead-in cabling.
- Rearrange a star-wired installation to support a single-ended, bus-wired or "Mode 3" configuration.
- Replace, relocate or otherwise alter the indoor lead-in cabling for any purpose including, but not limited to, building alterations or to improve the performance of a service.
- Disconnect a changeover (C/O) switch connected to **nbn**'s lead-in cabling.
- Install, relocate, replace or, under certain conditions (as detailed in section 4.1), remove a centralised filter connected to **nbn**'s lead-in cabling.
- Bypass, replace or utilise the existing NTD.
- Install a new NTD or change a line module in an existing NTD.
- Replace existing connection box/ wall box with a **nbn** connection box.
- For **nbn** lead-in cabling not exceeding a total capacity of ten (10) pairs and which does not terminate on a customer MDF, disconnect underground or aerial lead-in cabling at the external surface of the building for the purpose of renovation, demolition or relocation of the building.
- Use **nbn** lead-in poles to support customer cabling.

The above activities may be performed independently or concurrently.



4.3 Scope of authorised work

This Section details the scope of the works that are authorised by **nbn**.

4.3.1 Replacement of the first TO

nbn authorises a cabling provider to replace the first TO i.e. the network boundary point, with a **nbn** TO or an external NTD.

4.3.2 Relocation of the first TO

nbn authorises a cabling provider to relocate the first TO i.e. the network boundary point to another location, subject to the general terms and conditions of 4.1 and the following:

- The TO shall only be relocated to another position in the same building.
- The TO location shall comply with siting details.
- The TO, if replaced, shall be with an Industry approved TO.
- The TO shall be cabled in accordance with AS/CA S009:2013.

No alterations shall be made to any part of the outdoor cabling except for:

- one-for-one replacement of conductor terminations or connectors at an existing outdoor connection device for the sole purpose of disconnecting the old cable for the first TO and reconnecting the replacement cable
- re-routing of the TO cabling on the outside surface of the building where indoor cabling is not practicable
- the relocation or replacement of an existing outdoor centralised filter
- the installation of a **nbn** NTD
- disconnection of the cabling for the purpose of renovation, demolition or relocation of the building

4.3.3 Fixed wall phone or other hard-wired telephones

nbn authorises a cabling provider to replace an obsolete fixed wall phone or other hard-wired telephone (excluding a payphone) with a TO for the purpose of connecting other customer equipment, subject to the general terms and conditions of 4.1.

4.3.3.1 Replacement or relocation

If the first TO is to be replaced or relocated then:

- The installation will meet Australian Standard AS/CA S009.
- If the existing telephone or replacement TO is to be relocated and is to be reconnected as the first telephone or TO after the building entry point, it shall be installed in accordance with the requirements detailed in 4.3.2.

nbn authorises a cabling provider to disconnect a fixed wall phone or other hard-wired telephone (excluding a payphone) if it is no longer required and advise the customer to return to the RSP, subject to the general terms and conditions of 4.1 and the following:



- If the aforementioned telephone is the first telephone connected to the line after the building entry point, it shall be replaced with a TO that complies with Australian Standard AS/CA S009.
- If the replacement TO is the first TO connected to the line after the building entry point and the required location of the TO is different to the location of the aforementioned telephone, it shall be cabled in accordance with the requirements of Section 4.3.2.

4.3.4 Star-wired TOs

nbn authorises a cabling provider to relocate a TO that has been star wired from a connection block/box, lightning protector block or other joint installed in the lead-in cabling, subject to the general terms and conditions in section 4.1 and either of the following:

- the first TO is defined as the network boundary point
- the TO shall be relocated without disturbing the aforementioned connection block/box, lightning protector block or joint
- the building cabling shall be reconfigured in accordance with AS/CA S009

4.3.5 Additional TOs

nbn authorises a cabling provider to cable an additional TO from a star-wiring point at existing connection point or an NTD in the subject to the general terms and conditions in section 4.1 and either of the following:

- The cabling shall be installed to meet Australian Standard AS/CA S009.
- The additional TO could be cabled from one of the existing star-wired TOs, in which case reconfiguration of the installation would not be necessary.
- A NTD shall be installed and that the star wiring point and the additional TO are connected on the “customer” side of the NTD.

4.3.6 Reconfiguration of nbn wiring

nbn authorises a cabling provider to rearrange a star-wired installation to support a single-ended, bus-wired or “Mode 3” configuration for connection of a VDSL2 service, monitored security alarm, personal response (emergency call/medical alert) system etc.

The arrangement shall be altered in accordance with Figure 6:

- The TO connected as the first TO for each service shall be replaced with an approved TO if required.
- The first TO shall be cabled in accordance with the requirements of section 4.3.2.

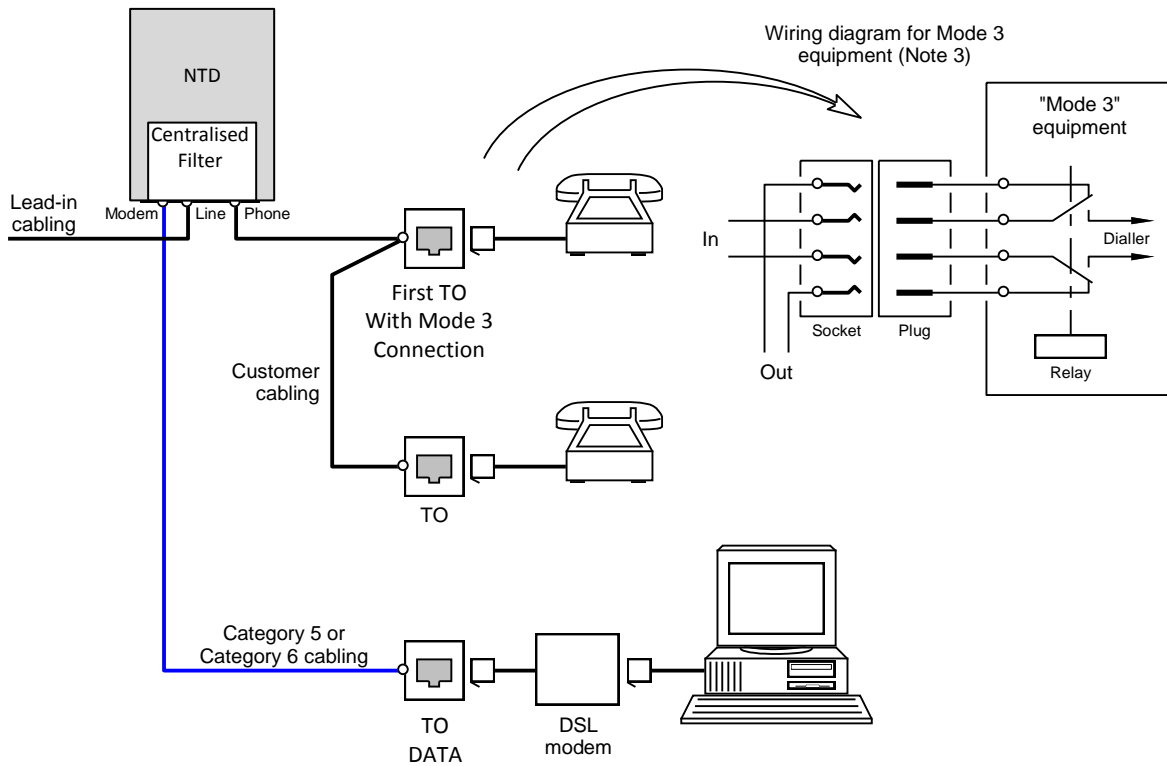

Figure 6. Typical wiring to facilitate “mode 3”

If a Mode 3 connection is required, e.g. for connection of a security alarm panel or a personal response (emergency call/medical alert) system, the “Mode 3” TO must be connected as the first connection point on the telephone side of the centralised filter, as shown above.



4.4 Cabling in the building

Where the cabling to the first TO “first socket” is altered, the existing indoor part of the lead-in cabling (between the building entry point and the first TO) may be re-used or otherwise shall be replaced, in whole or in part, with PVC or polyethylene-sheathed cable with at least the same number of pairs as the existing cable. Category 5 (or “5e”) or Category 6 cable is recommended for all new indoor cabling due to the number of pairs (4 pairs) and its noise and crosstalk immunity for VDSL2 services, and shall be ACMA Compliant and have a solid copper conductor with a diameter of 0.4 mm or 0.5 mm

Any cable that is run as outdoor surface cabling and not enclosed in conduit shall be ACMA rated outdoor type cable

Any cable that is run internally within the premises shall be ACMA rated indoor cabling for its flame retardant properties and meeting Australian Building codes.

4.4.1 Cable installation

The lead-in cable shall be installed in a manner consistent with the wiring rules (Australian Standard AS/CA S009) in respect of separation from other services, colour of conduit, etc.

Lead-in cabling that is run horizontally along an external wall shall be installed at least 100 mm above finished ground level. Lead-in cable on external walls shall be enclosed in conduit unless the cable is installed higher than 2.4 m or is protected from impact or abrasion by an overhang or similar building feature. Cable may be run as surface cabling without enclosure in conduit along a beam, fascia, soffit moulding, etc. Corrosion-resistant and UV-resistant cable fastenings shall be used on external surfaces.

Surface cabling on internal surfaces may be enclosed in plastic conduit, ducting or trunking, or may be stapled or clipped directly to a suitable timber support (e.g. skirting, architrave).

Outdoor or indoor cable, conduit, ducting or trunking shall be run vertically or horizontally unless it is run in parallel with a sloping building feature (e.g. bargeboard or raked ceiling), and should be run along or adjacent to suitable building features or fittings so as to be unobtrusive.

Lead-in cable installed on any surface without enclosure in conduit shall be fastened at distances no greater than:

- 500 mm for vertical cable runs
- 300 mm for horizontal or diagonal runs

The cable bend radius for cable sizes of 2 to 5 pairs shall not be less than 25 mm (at least 50 mm bend radius is recommended for 4-pair and 5-pair cable). The cable shall be fastened on each side of the bend as shown in Figure 5 (machine stapling of Category 5/5e or Category 6 cable is not recommended unless the stapler is a type that limits the staple tension exerted on the cable sheath and is correctly adjusted).

Where conduit is used, rigid conduit should be used for straight or long cabling runs but corrugated (flexible) conduit may be used for short cable runs or difficult bends on the surface of the wall.

Conduit couplings and fittings should be glued or arranged to prevent the entry of water and so as to allow any water that may get in to drain out. An example of a suitable arrangement that does not require the conduit couplings to be glued is if the socket is above the spigot for vertical or diagonal conduit runs.

Note: Any indoor type cable that is continually immersed in water within the conduit will be prone to failure.

Conduit or ducting/trunking shall be fastened at distances no greater than:

- 900 mm for vertical rigid conduit or ducting/trunking
- 450 mm for vertical corrugated (flexible) conduit
- 600 mm for horizontal or diagonal rigid conduit or ducting/trunking
- 300 mm for horizontal corrugated (flexible) conduit

Outdoor conduits shall be fastened using galvanised saddles or half-saddles. For indoor conduits, nickel-plated or zinc-passivated saddles or half-saddles may be used.

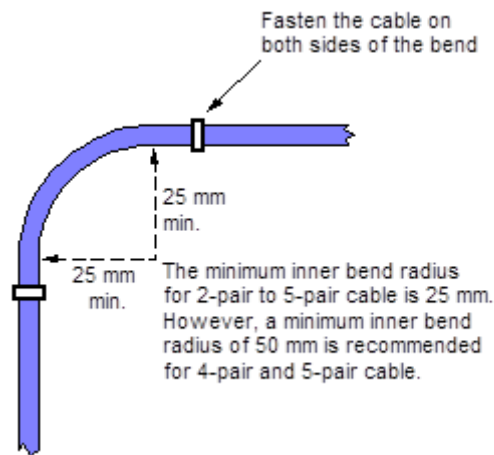

Figure 7. 2pr – 5pr cable minimum bend radius

Note: Fasten the cable immediately before and after the bend, not in the middle of the bend.

4.4.2 Building cable entry

Any cable running down the cavity of an external wall should have a “gooseneck” (half loop) formed in it to provide a “drip point” so that any condensation or seepage water flowing down the cable does not run into the TO or onto the internal wall lining. Where sarking or panel bracing has been installed between the inner and outer walls, ensure that the drip point is provided on the outside (external wall side) of the sarking membrane or bracing panel. If it is necessary to drill a hole through external wall cladding for cable entry, drill at an upward angle into the wall cavity to ensure that any water running down the outer wall will not flow through the hole into the building.

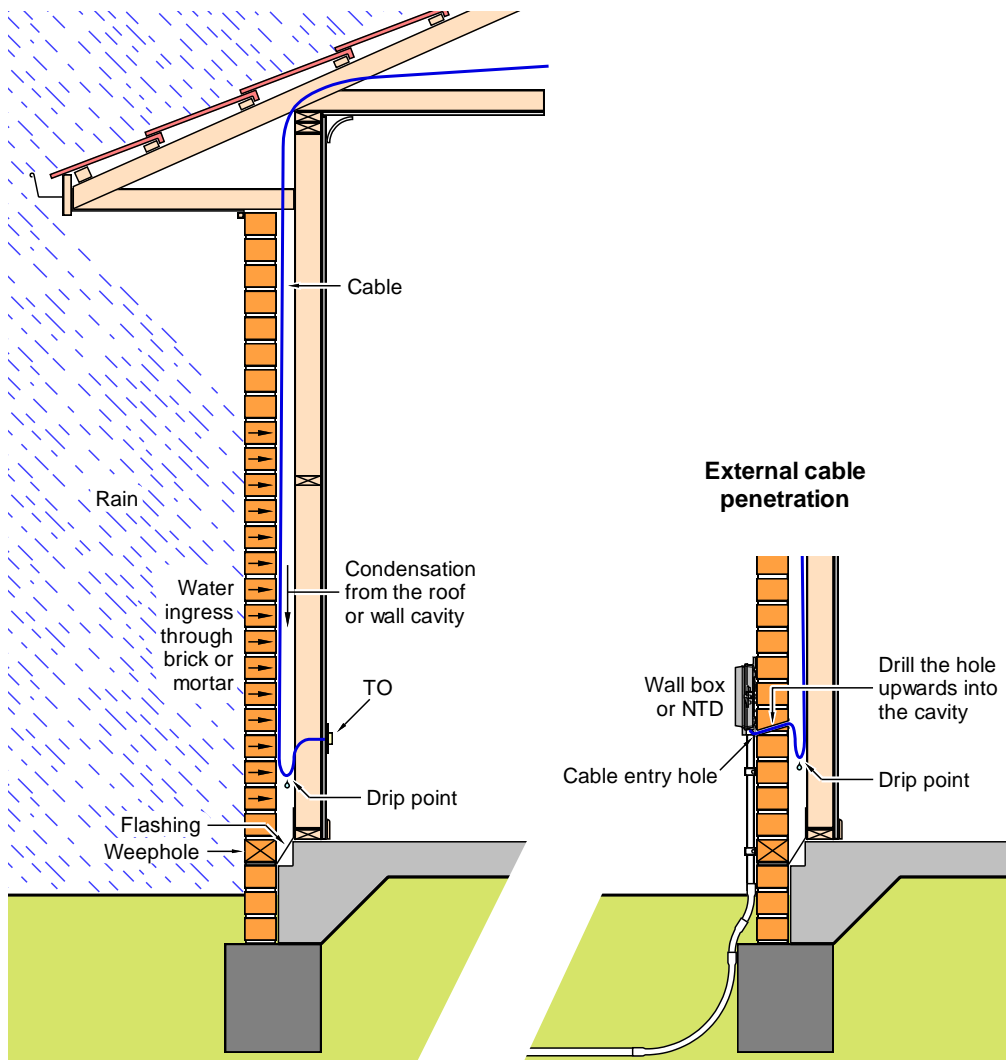

Figure 8. Building cable entry

The drip point consists of slack cable (min. 200 mm, max. 500 mm) left in the wall cavity and arranged such that it is looped downwards.

The drip point (slack cable) should be located on the outer side of any wall sarking or panel bracing (i.e. between the external brick or external wall cladding and the sarking/bracing).

For any external cable penetration to the building, drill the hole upwards into the wall cavity so that any water running down the external wall will not run through the hole into the building.

All Installation works shall adhere to Australian Standard AS/CA S009, Installation requirements for customer cabling (Wiring rules) and the building code of Australia.



4.5 Cable jointing

No joints shall be made in any part of the outdoor lead-in cabling except for:

- like-for-like replacement of conductor terminations or connectors in an existing outdoor connection device for the purpose of disconnecting the old cable between it and the first TO and reconnecting a replacement cable; or
- installation of a **nbn** NTD
- Replacement of a connection device/wall box other than a NTD with a **nbn** connection box
- Installation of a centralised filter

Where it is proposed to join a new cable to the existing lead-in cable:

- The cabling provider shall make no more than one joint in the lead-in cable between an existing outdoor connection device or, where there is no outdoor connection device, the building entry point, and the first TO
- The new cable shall replace part or all of the existing cable and shall not be teed (star wired) into the existing cable
- The joint shall be installed in an accessible location (e.g. accessible underfloor or roof space or behind a wall plate in a wall cavity) and shall be suitably constructed, enclosed, positioned and supported to prevent physical damage or the ingress of dust, insects, vermin and moisture
- The joint shall be made using moisture resistant connectors, Scotchloks 2 port-UY, using the crimping tool specified by the manufacturer of the connectors. Pair twist shall be maintained as close as possible to the connectors
- All pairs of the existing cable shall be jointed through to the first TO using the corresponding pairs of the new cable unless the joint is being made in an outdoor **nbn** NTD, in which case only working pairs shall be connected

4.6 Change over switch

nbn authorises a cabling provider to disconnect, an existing C/O switch connected to **nbn**'s lead-in cabling if required, subject to the general terms and conditions of 4.1 and the following:

- Where the C/O switch is disconnected, **nbn**'s lead-in cable shall be terminated on a TO
- If the location of the replacement TO is different to the location of the C/O switch, it shall be cabled in accordance with the requirements of section 4.3.2
- If the original need for the C/O switch has lapsed, a cabling provider may permanently disconnect the C/O switch, as long as the TO that is connected as the first TO complies with section 4.3.2
- **nbn** does not authorise a cabling provider to install a new C/O switch in **nbn** lead-in cabling
- a NTD shall be installed in accordance with section 4.6 such that the C/O switch is connected on the customer side of the NTD



4.7 VDSL2 centralised filter

nbn authorises a cabling provider to install or replace a centralised filter (also referred to as a central splitter or remote splitter) within the **nbn** lead-in, subject to the general terms and conditions of 4.1 and the following:

- The centralised filter shall be certified as compliant to AS/CA S041.3:2015 or later.
- **nbn** approved centralised filters are detailed in appendix A.1. These shall be housed within either an NTD or TO integrated faceplate as detailed in Appendix 6 A.4

A cabling provider may install or replace a VDSL2 centralised filter in the lead-in cabling as long as all of the following conditions are met:

- The centralised filter shall be located in or on the same premises as the modem
- If the centralised filter is to be installed outside the building (i.e. on an external wall), it shall be installed within an NTD
- The TO socket to be used for connection of the VDSL2 modem shall be legibly and durably marked “DATA” or similar
- Any new or replacement cable provided between a **nbn** lead-in connection device and the centralised filter shall be Category 5 (or “5e”) or Category 6 cable
- Any new or replacement cable provided between the centralised filter and the TO for the DSL service should be Category 5 (or “5e”) or Category 6 cable

Replacement of an existing filter connected to the lead-in cabling.

A cabling provider may remove an existing centralised filter if the lead-in is terminated on a single TO (without star or bus wired additional TO) for dedicated connection to a VDSL2 CPE.

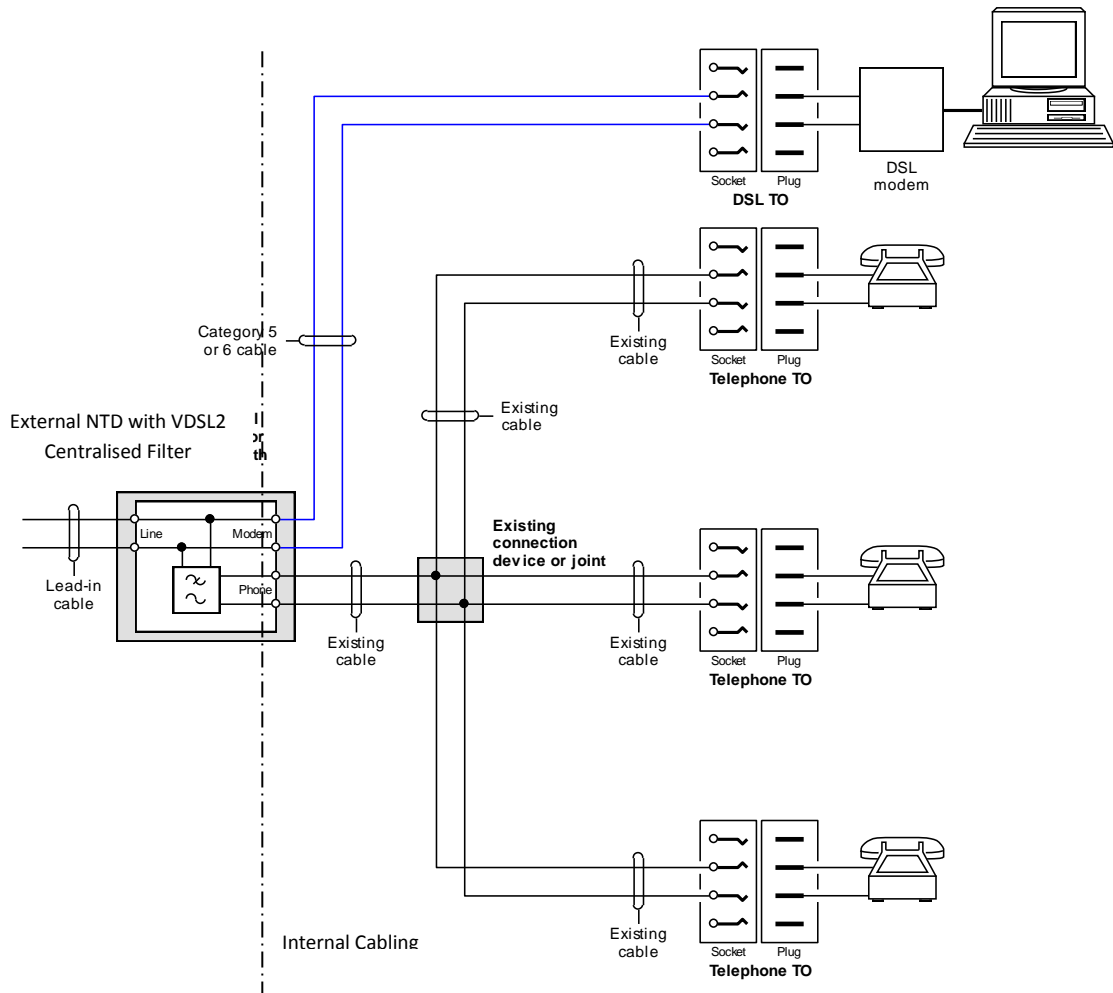

Figure 9. Typical VDSL2 centralised filter installation within external NTD for existing star legacy wiring

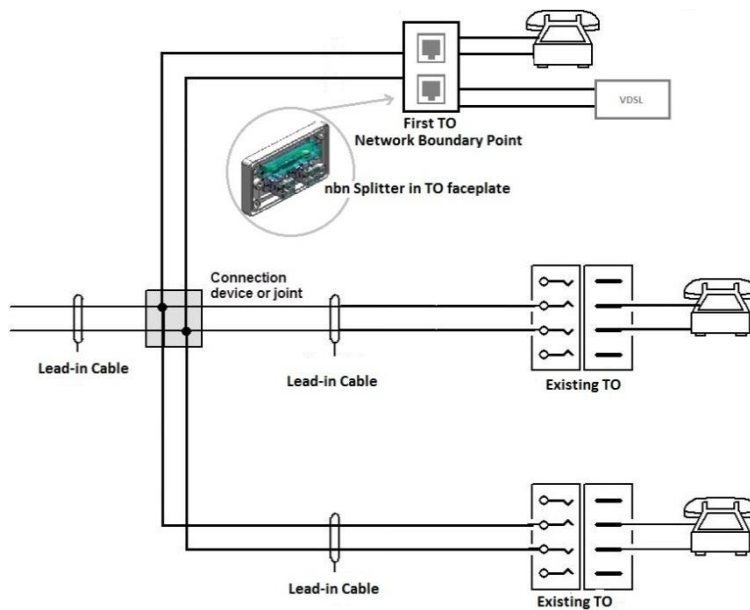

Figure 10. Typical nbn VDSL2 centralised filter faceplate installation in legacy star-wired installation



4.8 Existing NTD

nbn authorises a cabling provider to use the existing NTD if deemed fit for purpose or replace with a new **nbn** NTD, subject to the general terms and conditions of 4.1 and the following:

- alterations to the existing NTD can be undertaken if the NTD is fit for purpose
- In cases where the existing NTD requires replacement, then the existing NTD is to be disconnected and a new like for like **nbn** NTD is to be installed
- The NTD shall not be replaced if the lead-in cabling has more than a total of 5 pairs (e.g. more than 1 x 5-pair cable or 2 x 2-pair cables) and referred back to the RSP/**nbn**
- Any new NTD to be installed shall be a NTD described in Appendix A
- The NTD shall be installed in accordance with this Document and per Australian Standard AS/CA S009
- An existing DSL line module shall not be replaced with a non-DSL line module, DSL Line module is to be replaced by the **nbn** VDSL2 centralised filter
- If an existing NTD containing OVP or Customer Lightning Protection (CLP) is to be replaced then the **nbn** equivalent NTD shall be used, **nbn** Part number 10023544 and fitted with **nbn** centralised filter modules and OVP (**nbn** Part number 10024460).

Note: Earth connection should always be equipotential bonded to the electrical system where possible to take advantage of the inbuilt lightning protection

Earth connection shall be made as per Australian Standard AS/CA S009, Installation requirements for customer cabling (Wiring rules) section 20.7

This may need to be undertaken by a licenced Electrician depending on the existing Earth arrangement at the premises.



4.9 nbn NTD

nbn authorises a cabling provider to install an **nbn** NTD where the existing Connection Device is damaged or otherwise not suitable for **nbn** or the network boundary location is being changed

Is subject to the general terms and conditions of 4.1 and the following:

- The existing NTD shall only be replaced with an **nbn** NTD device that is marked with NTD.
- The **nbn** NTD Installation is a like for like Installation, inclusive of OVP and earthing arrangements.
- The **nbn** connection box shall only be used when replacing a connection device, I.E a “Luca Box” or Wall Box and not a NTD.
- The NTD shall only be installed if the **nbn** lead-in cabling has no more than a total of 5 pairs (e.g. no more than 1 x 5-pair cable or 2 x 2-pair cables).
- The NTD shall only be used to connect a single household (inclusive of a “home office” or “granny flat”) or a single office/business.
- The NTD shall not be used to connect a cable from another carrier’s network other than a cable connected between the customer side of that carrier’s NTD, first TO, fixed wireless terminal, satellite terminal or a customer MDF and the customer side of the **nbn** NTD.
- The NTD shall be located on the external wall of the same building in which the telecommunications service(s) will be used by the customer and shall not be installed at any point away from the building (e.g. at a fence, pole or any other detached structure).
- The new NTD to be used shall be the NTDs described in Appendix A.
- The NTD must be installed on the external wall of the customer’s building as close as practicable to the building electrical switchboard for earthing requirements as required. For a new building under construction, the preferred location is below the electricity enclosure to ensure the NTD will be clear of downpipes or adjoining fences.
- The NTD must be installed no less than 500 mm and no more than 1300 mm from finished ground level (measured to the bottom of the NTD). For a new building under construction, the preferred height is 600 mm above finished ground level (measured to the bottom of the NTD) to ensure that adequate clearance is maintained from an electricity enclosure located above the NTD.
- The NTD must be installed on a vertical surface with the cable entry ports at the bottom.
- The **nbn** NTD must not be mounted sideways, obliquely or upside down.
- Any cables exposed on the surface of the building must be protected by conduit.
- The **nbn** lead-in cable must enter the cable entry port at the bottom left of the NTD and customer cables must enter the cable entry port at the bottom right of the NTD. Cables must not enter the rear, side or top of the NTD.
- The grommets/glands must not be removed.
- The customer shall be informed of the existence of the NTD as there new Network boundary Point.



- Adequate clearance must be provided around and in front of the NTD, in accordance with Appendix D of Australian Standard AS/CA S009 (wiring rules), to provide safe and convenient access by **nbn**, service providers, cabling providers and customers.

4.10 Disconnection of nbn lead-in cabling

nbn authorises a cabling provider to disconnect underground or aerial **nbn** lead-in cabling at the external surface of a building for the purpose of renovation, demolition or relocation of the building, subject to the general terms and conditions of 4.1 and the following:

- The lead-in cable shall only be disconnected if the total capacity of the lead-in cabling does not exceed 10 pairs and does not terminate on a customer MDF.
- If a span of aerial lead-in cable is detached from the building for the purpose of renovations, painting or demolition, and the cable is not required to be cut, the cable and conduit shall be unfastened and suitably supported so as to protect them from damage and it shall be reattached to the building to comply with Australian standards AS/CA S009.
- If the underground or aerial lead-in cabling is disconnected for the purpose of demolition or relocation of the building, and is required to be cut then it is to be cut at or as close as reasonably practicable to the external termination device or if none are available to the building entry point.
- The cut cable is to have conductors individually insulated and sealed.
- Unsupported lead-in cable exceeding a length of 500 mm shall be tied in a loop and marked “**nbn** lead in cable”.
- In case of aerial Lead in cable the coiled up loop shall be tied to the last pole at height greater than 2.7 m above ground level measured to the lowest point of the coil.
- The lead-in cabling shall be reconnected utilizing an NTD or TO.

4.11 Use of existing telecom lead-in poles for customer cabling

nbn authorises a cabling provider to use existing lead-in poles to support aerial customer cabling subject to the general terms and conditions of 4.1 and the following:

- Only poles that are located within the boundaries of the customer’s premises shall be used.
- The poles shall only be used if sufficient pole height is available to install the customer cabling in accordance with the requirements of the wiring rules (Australian Standard AS/CA S009) while maintaining the required separation from the **nbn** aerial cable and fittings.
- The customer cabling shall be installed and maintained at the customer’s cost, including transfer of the cabling to any pole subsequently condemned and replaced by **nbn**.
- Only poles erected at the customer’s cost may be used.
- Only existing telecom poles located within the boundaries of the customer’s premises may be used. Existing Telecom poles located outside the customer’s property boundary shall not be used for customer cabling.



- The poles must be of sufficient height and the **nbn** lead-in cable must be installed on the poles at sufficient height to allow installation of the customer cabling in accordance with the following:
 - The customer cabling shall be installed below the aerial **nbn** cabling.
 - The customer cable and associated pole fittings shall be separated from the lead-in cable and associated pole fittings by at least 300 mm at the pole.
 - The customer cable shall be separated in-span from the lead-in cable by at least 300 mm.
 - The customer cabling shall be installed in accordance with the relevant requirements of the wiring rules (Australian Standard AS/CA S009) including minimum ground clearances.
 - The customer cable shall not be installed within any **nbn** or existing telecom underground conduit or pit or within any **nbn** or existing Telecom conduit installed on the pole.

Note: For safety reasons, **nbn** will not use customer-owned poles to support **nbn** cabling but will allow **nbn**-owned poles erected at the customer's cost to be used to support the customer's aerial LV power mains or customer cabling.

nbn should be advised of this requirement in advance of commencement of pole installation so that **nbn** can ensure that the poles used are of sufficient height to support additional cables.



5 Activities not authorised

This Document does not authorise a cabling provider to do any of the following:

- Use or alter any part of the underground or aerial **nbn** lead-in cabling between the property entry point and the building other than disconnect cabling not exceeding a total capacity of 10 pairs at the building for the purpose of renovation, demolition or relocation of the building.
- Connect or reconnect any underground or aerial lead-in cabling that has been cut at the external surface of the building for the purpose for the purpose of renovation, demolition or relocation of the building unless the lead-in cabling has been cut during building renovation for the eventual purpose of installing a **nbn** NTD.
- Disconnect the **nbn** lead-in cable and leave it permanently disconnected from any customer-accessible to other than where necessary for the purpose of renovation, demolition or relocation of the building.
- Totally remove **nbn**'s facilities from the building other than for the purpose of renovation, demolition or relocation of the building.
- Alter or disconnect any **nbn**'s lead-in cabling exceeding a capacity of 10 pairs.
- Alter or disconnect any payphone installation.
- Alter or disconnect any coaxial cabling used to supply a FOXTEL pay TV service.
- Alter or disconnect any optical fibre cabling.
- Alter or disconnect any **nbn**'s lead-in cabling in a power generating station or a high voltage distribution substation.
- Alter or disconnect any **nbn**'s lead-in cabling in a hazardous area (explosive atmosphere) as defined in Australian Standard AS/CA S009.
- Star wire an additional TO from an existing connection block/box or joint in **nbn**'s lead-in cabling (other than a **nbn** NTD), or install a new terminal block/box or joint (other than a **nbn** NTD) in the lead-in cabling for the purpose of star-wiring TOs.
- Connect **nbn**'s lead-in cable directly on a home distributor or home networking box.
- Connect **nbn**'s lead-in cable on any customer MD, or disconnect or alter any **nbn**'s lead-in cabling that terminates on a customer MDF.
- Disconnect or remove any NTD so as to change the network boundary from the NTD to the first TO "(first socket)" or any other connection point.
- Disconnect or remove any Centralised Filter (also referred to as a Central Splitter or remote splitter) connected to **nbn**'s lead-in cabling or provided within an existing NTD other than to replace it with another type of **nbn** NTD containing a centralised filter described in Section 4.7 unless 1) its disconnection or removal is essential to the proper functioning of a proprietary high-speed data service or 2) the lead-in is terminated on a single TO (without star or bus wired additional TO) for dedicated connection to a VDSL2 CPE.
- Disconnect **nbn** lead-in cabling for the purpose of migrating services from **nbn**'s copper twisted pair network to a different telecommunications network technology such as FTTP (Fibre to the Premises), fixed wireless or satellite.



- Bypass an existing NTD containing OVP with an NTD not containing OVP.
- Removal of Earth connections from an existing NTD unless moving the earth to the new **nbn** NTD that contains OVP.
- Screw terminals of any description shall not be used for connection or jointing of **nbn** lead-in conductors.

Alteration of **nbn** lead-in cabling or network boundary facilities is not authorised where any the following devices or equipment is connected at the first point (whether hard-wired or plug-connected):

- any type of line multiplexing, line conditioning or line conversion equipment (e.g. a small pair-gain system)
- a payphone;
- a functioning Integrated Services Digital Network (ISDN NT1) or Analogue Network Termination Type 1 (ANT1)



6 Glossary

Term	Description
CAN	Customer Access Network (also referred to as the “local loop”)
Category 5 (or “5e”)	Cable or connecting hardware that is designed and manufactured to carry signals with a nominal maximum frequency of 100 MHz
Cat 6	Cable or connecting hardware that is designed and manufactured to carry signals with a nominal maximum frequency of 250 MHz
CLP	Customer Lightning Protection for surge suppression (also known as OVP)
C/O switch	Changeover switch — a switch used to connect a line to either one point (e.g. a telecommunications outlet) or another
Cth	Commonwealth (law) (as distinct from State law)
DSL	Digital Subscriber Line
IDC	Insulation Displacement Connector
ISDN	Integrated Services Digital Network - a digital telecommunications network service that allows connectivity to various public or private networks for either voice or data transmission
MDF	Main Distribution Frame
MRC	Moisture Resistant Connector
NTD	Network Termination Device
OVP	Over Voltage Protection
RJ11	Registered Jack No. 11 (or 12) — a term commonly (but incorrectly) used to describe a 6P modular plug or socket
RJ45	Registered Jack No. 45 — a term commonly (but incorrectly) used to describe an 8P modular plug or socket
TO	Telecommunications Outlet, A fixed connecting device to which an end-user may connect customer equipment to telecommunications cabling. A telecommunications outlet includes the socket(s) and associated mounting hardware (e.g. wall plate)
VDSL2	Very High Rate Digital Subscriber Line

Appendix A Approved Lead-In Equipment

A.1 nbn NTDs and connection box

A.1.1 Connection box 1-2 lines



Figure 11. nbn connection box 10023542

nbn Part Number – 10023542

- 1-2 lines
- Scotchlok Termination
- IP53
- Not Marked as NTD

A.1.2 Compact NTD

- NTD Enclosure 1-2 Lines
- Suits up to 2 x VDSL2 centralised filters
- Scotchlok termination.
- IP53
- Marked with NTD



Figure 12. nbn compact NTD 10023656



Figure 13. nbn with unterminated cables



Figure 14. nbn NTD with VDSL2 centralised filter installed

A.2 Network terminal device



Figure 15. nbn NTD 10023544

nbn part number - 10023544

- 1-6 Lines
- IP54
- 6 X VDSL2 centralised filters
- Earth Termination Location
- External Installation Only
- Marked with NTD

A.3 TO (Telecommunications Outlet)



Figure 16. nbn faceplate

nbn Part Number – 10023548

- Faceplate Dual Outlet
- In built VDSL2 centralised filter - Voice and Data preterminated to RJ45 sockets
- Line in – Scotchlok termination.
- Flush or surface mounted
- Internal Installation – Only

A.4 Centralised filters

A.4.1 VDSL2 Centralised filter with OVP/CLP



Figure 17. nbn VDSL2 centralised filter

nbn part number - 10024460

- Built in Over Voltage Protection
- VDSL2 centralised filter
- Earth Connection
- Tool less termination
- Only compatible for installation in **NTD nbn part number - 10023544**

A.4.2 VDSL2 centralised filter

nbn – Part Number 10023888

- VDSL2 centralised filter
- Scotchlok termination
- Face plate installation **nbn** part No 10023548 or **nbn** Compact NTD part No 10023656

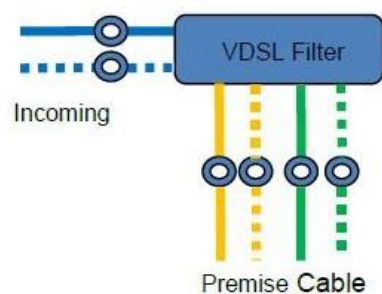
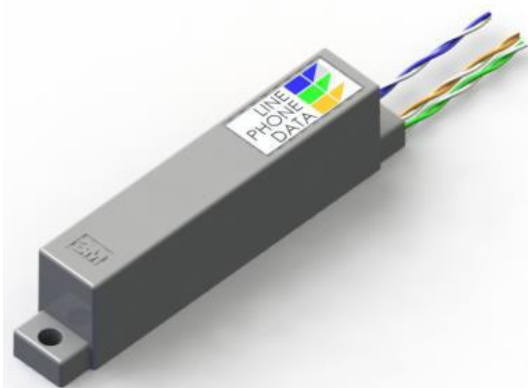

Figure 18. nbn VDSL2 centralised filter

A.5 Cable connectors



Figure 19. Connectors and crimping tool

The connectors approved for use are the Scotchlok 2 port-UY

nbn Part Number - 10023536

- to suit 0.40 mm to 0.90 mm diameter solid copper conductors
- Moisture resistant Gel filled

The connectors shall be used in accordance with the manufacturer's instructions and shall be crimped using the tool recommended by the manufacturer of the connectors.